

## Chest Freezer Sliding Glass Lid Novelty Freezer 71" Long

ITEM # \_\_\_\_\_

MODEL # \_\_\_\_\_

NAME # \_\_\_\_\_

SIS # \_\_\_\_\_

AIA # \_\_\_\_\_



738234 (KCNF170WH)

Sliding Glass Lid Novelty  
Freezer 71" Long

### Short Form Specification

Item No. \_\_\_\_\_

Flat lid novelty freezer with tempered glass sliding lids and unobtrusive frame around the glass lids to ensure maximum visibility. Internal and external structure in white painted steel. Fan cooled condenser for best preservation performance even in heavy-duty conditions. Basket, vertical basket divider, NSF thermometer and lock included as standard. Defrost water drain with plug for easy cleaning. R290 refrigerant gas for the lowest environmental impact (GWP=3). The temperature range is -10° to 10°F. ETL safety and sanitation listed for US and Canada. Equipped with NEMA 5-15P plug.

### Main Features

- Fan cooled condenser to cope with heavy duty conditions
- Hydrocarbon refrigerant gas R290 for the lowest environmental impact (GWP=3) - CFC and HCFC free.
- Included as standard 1 NSF® certified temperature gauge and 1 basket (including one vertical divider) durable and reliable for safety in food storage
- Removable rubber bumper guards
- Bottom drain with plug for easy interior cleaning and defrost water discharge
- Mechanical control panel with adjustable temperature
- Low energy consumption

### Construction

- Tempered glass sliding lids
- Exterior and Interior finish in white painted Steel
- Locking lids and key protect the contents of the unit
- Mounted on heavy-duty casters, two locking to keep unit in place but allows position adjusting.

### Sustainability

- CFC and HCFC free, highly ecological refrigerant type: R290 (ecological gas in foam: cyclopentane). Hydrocarbon refrigerant gas R290 for the lowest environmental impact (GWP=3), to reduce green house and ozone depletion effects.
- Hydrocarbon refrigerant gas R290 for the lowest environmental impact (GWP=3) - CFC and HCFC free.
- High efficiency components to minimize the energy consumption still guaranteeing the highest performances.

### Optional Accessories

- Basket for Glass Lid Chest Freezer PNC 882001   
22.52x10.51x12.52 in  
(572x267x318 mm)

APPROVAL: \_\_\_\_\_

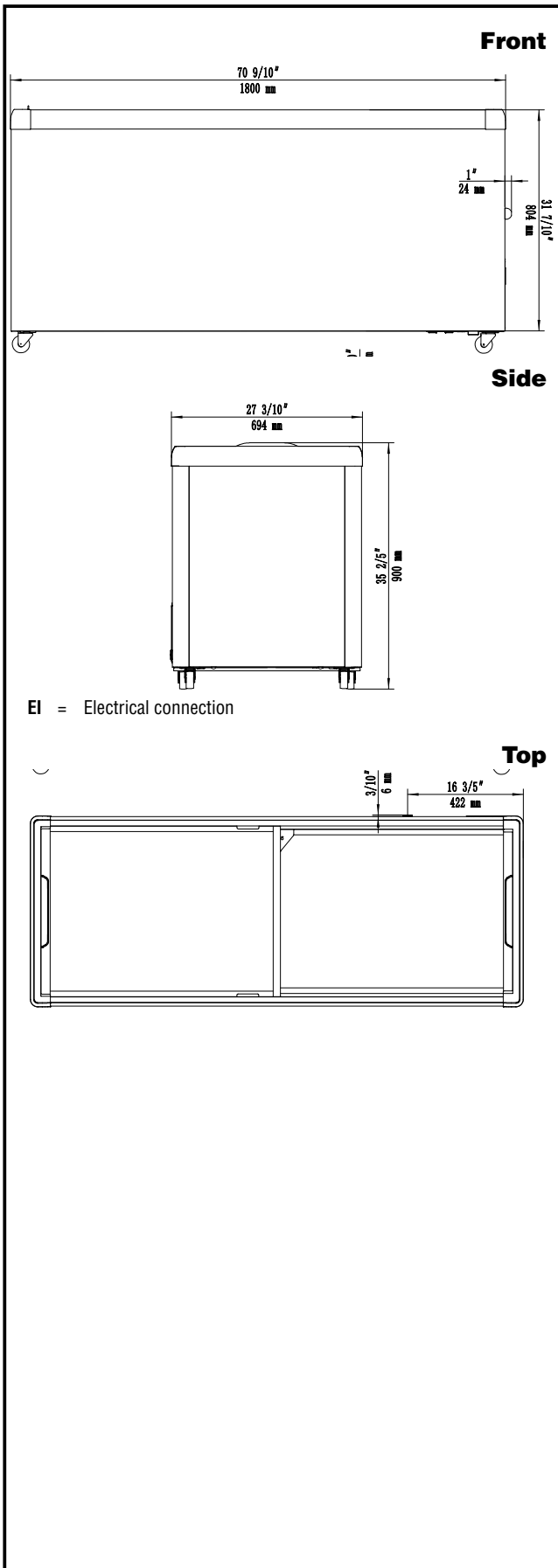

## Electric

Supply voltage:	738234 (KCNF170WH)	115 V/1 ph/60 Hz
Electrical power, max:		0.3 kW
Plug type:		USA NEMA 5-15P

## Capacity:

Gross capacity:	23 cu.feet
-----------------	------------

## Key Information:

External dimensions, Width:	70 13/16" (1799 mm)
External dimensions, Depth:	27 5/16" (694 mm)
External dimensions, Height:	34 5/8" (880 mm)
Condenser type:	Static
Freezer baskets (Number/Type):	1 / Wire
Control	Mechanical
Warranty	1/5 Years
Internal Dimensions (depth):	21 5/8" (550 mm)
Internal Dimensions (height):	26 13/16" (681 mm)
Internal Dimensions (width):	65 3/16" (1655 mm)
Net weight:	209 lbs (95 kg)
Shipping width:	30 1/2" (775 mm)
Shipping height:	40 3/4" (1035 mm)
Shipping weight:	243 lbs (110 kg)
Shipping volume:	53.02 ft <sup>3</sup> (1.5 m <sup>3</sup> )
Approvals	;ETL C&US;ETL SANITATION

## Refrigeration Data

Temperature display location:	Internal
Compressor power:	1/2 hp
Operating temperature min.:	-23.8 °F
Operating temperature max.:	-0.4 °F

## Sustainability

Current consumption:	4.1 Amps
Refrigerant type:	R290
Refrigerant weight:	135 g



Chest Freezer  
Sliding Glass Lid Novelty Freezer 71" Long

The company reserves the right to make modifications to the products without prior notice. All information correct at time of printing.